



NATIONAL INSTITUTE OF TECHNOLOGY, WARANGAL– 506004
TELANGANA (INDIA)

Tender Notice No. NITW/CS-2/2018-19/

Date: 31-05-2018

INVITATION FOR TENDERS FOR SUPPLY OF
Seminar Hall Chairs

Established registered firms/companies with proven track record and experience of **05 years** in the supply of Seminar Hall Chairs are invited to submit their most competitive bids on or before **18-06-2018 at 11.00AM**. The bids are to be sent in a sealed envelope super scribing the **Reference No. & Name of the item clearly on the envelope** addressed to

**TENDER BOX,
C/O DIRECTOR,
NATIONAL INSTITUTE OF TECHNOLOGY
WARANGAL-506 021 (T.S.)**

Important Dates:

1.	Tender Opening	on 18-06-2018 at 11.30
-----------	-----------------------	-------------------------------

The bids will be opened in the presence of the bidders or their authorized representatives along with the authorization letter who choose to attend as per the terms and conditions mentioned below. No bid will be accepted after the due date and time. [Even if accepted will be returned unopened.]

Interested eligible bidders may download the set of bidding documents and formats given as Annexures etc. from our website: www.nitw.ac.in. The payment towards the cost of the tender documents and EMD in the form of Demand Draft or **Fixed Deposit Receipt (FDR) or Banker's Cheque** from any **Nationalized Bank** in favour of **“Director, NIT Warangal”**. EMD any other form will not be accepted. The offer without tender fee / cost of documents and EMD will be rejected summarily.

Cost of Tender Documents -Rs. 1,500/-+ GST @ 18%

EMD -Rs.5,00,000/- (Rupees Five lakhs only)

The Institute GSTN/IEC details are as follows.

GST No.	36AACAN7241H2ZK
----------------	------------------------

No interest will be paid on the EMD. The EMD will be forfeited, if the supplier withdraws his tender during the validity period of the bid. Offer without EMD and tender fee will be rejected summarily.....

I. GENERAL CONDITIONS OF CONTRACT (GCC):

- (1) **Validity of the offer:** The Offer shall be valid for **90** days from the date of opening of the quotation.
- (2) **Clarification of bids:** During opening or evaluation, the purchaser may at its discretion, seek the required clarification from the bidders. However, no change in prices or substance of the bid shall be sought, offered or permitted. If the bid is not substantially responsive, it will be rejected by the Purchaser. Unsigned communication/ bids will not be accepted and will be rejected summarily.
- (3) **EMD:** EMD for the specified amount shall be submitted along with the bid in the form of Demand Draft or FDR or Bankers Cheque of any **Nationalized Bank** in favour of “**Director, National Institute of Technology Warangal**”, Payable at Warangal. No interest will be paid on the EMD. The EMD will be forfeited, if the supplier withdraws his tender during the validity period of the bid. Offer without EMD and tender fee will be rejected summarily.
- (4) **Prices:** The price quoted shall be on FOR Destination basis. The quoted price shall also include installation & commissioning, Standard Warranty period of ONE year. However, the quote should indicate the basic price, discount, other duties/taxes and levies separately (Format under the heading **FINANCIAL BID** is enclosed as Annexure-II to this bid document). Concessions extended to Educational Institutions, if any shall be mentioned in the quotation.
- (5) **Payment:** Payment will be made through RTGS/NEFT upon receipt of ordered items and its acceptable satisfactory performance and on production of bank guarantee at the rate of 10% of the order value.
- (6) **Evaluation:** Evaluation of the Bids shall be made strictly in terms of provisions and criteria disclosed in the bidding document for the quantities mentioned in the bid. However, the Institute reserves the right whether to purchase the total quantities or in part thereof.

Notwithstanding the above, the Purchaser reserves the right to accept or reject any quotation, cancel the bidding process and reject all quotations at any time prior to the award of the contract. Also, the Director reserves the right to cancel the purchase order if the firm fails to comply with the delivery schedules without any notice and bid security/EMD in any form will be forfeited.
- (7) **Delivery period:** The ordered item shall be delivered as per the schedule given in the SCC at Sl. No.(10)
- (8) **Liquidated Damages:** The Institute reserves the right to impose ‘LD’ if the supplier fails to perform the contract within the specified period and can even terminate the contract on the whole or in parts thereof. The rate of LD would @ 1 % per week subject to a maximum of 10 %.
- (9) **Security deposit:** The successful tenderer will have to deposit @ 5% of the order value within 07 days of issuance of LOI/order towards security deposit. Else the offer is liable for rejection and the EMD will be forfeited.

- (10) **Performance Security**: The Institute reserves the right to insist for performance security @ 10% of the order value towards warranty obligations.
- (11) **Inspection and tests**: The purchaser's right to inspect, test and, where necessary, reject the Goods after the Goods' arrival at Site shall in no way be limited or waived by reason of the Goods having previously been inspected, tested and passed by the purchaser prior to the goods shipment. The Inspection and test certificates shall accompany the goods/invoice.
- (12) **Sample**: samples shall be provided by the supplier at the entire cost and risk of the supplier.
- (13) **Defective material**: The defective material/samples from premises of NIT Warangal will be lifted at the entire cost & risk of the firm and the defective material will be lying at their own risk and cost.
- (14) **Packing**: Each package shall have marked with (i) Order No., (ii) Reference number of the packing list and (iii) supplier's name on three sides of the package with proper paint/indelible ink.
- (15) **Delivery and Documents**: Upon delivery of goods, the supplier shall notify the purchaser and Insurance company by fax the full details of the shipment like contract No., description of the goods, quantity and name of the consignee etc., Also, the supplier shall mail copies of the documents like, Supplier's Invoice, RR/LR, packing list, insurance certificate, warranty certificate and inspection certificate issued by the concerned agency/factory etc.,
- (16) **Corrupt or Fraudulent practices**: The bidders shall observe the highest standard of ethics during the whole transaction. Contrary to the above the offer will be rejected for award of contract and firms will be declared as ineligible even for further period as deemed fit by the Institute.
- (17) **JURISDICTION**: The Courts of Warangal alone will have the jurisdiction to try and any matter dispute or reference between the parties arising of this agreement/contract.
- (18) **Indexing the bid documents**: All pages of the Bid Documents shall be numbered and the first page shall be the table of contents. (Format enclosed as Annexure –I) to this bid document) and the last page shall be the declaration certificate (format enclosed as Annexure – VII)

In addition, the Special Conditions of Contract (if mentioned along with the specifications of the item) shall supplement these General Conditions of Contract. Wherever there is a conflict, the provisions mentioned in the SCC shall prevail over these General Conditions of Contract.

Please note that the institute reserves the right to accept or reject any bid and to annul the bidding process and reject all bids at any time prior to the award of contract, without thereby incurring any liability to the affected Bidder or bidders.

Signature

Name: _____

Designation: _____

Date & Seal

of the competent authority of the firm

SPECIAL CONDITION OF CONTRACT (SCC)

SEMINAR HALL CHAIRS

Qty. 3,500 - 4,000 Nos.

Chair Dimensions

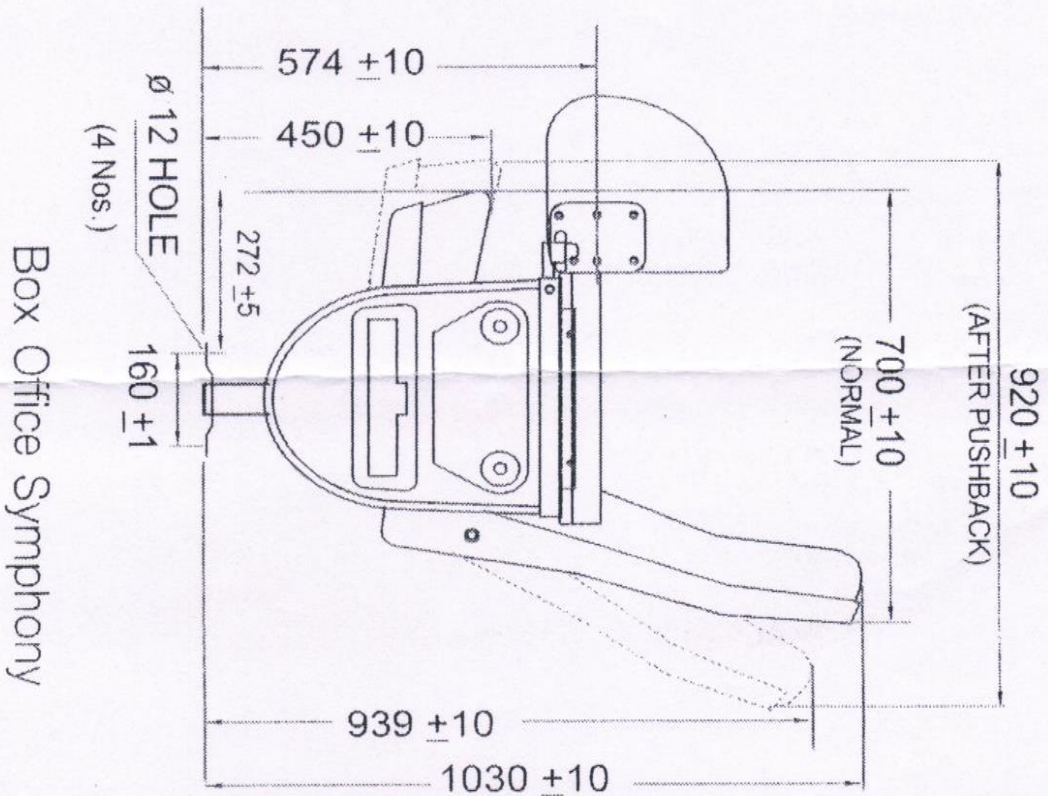
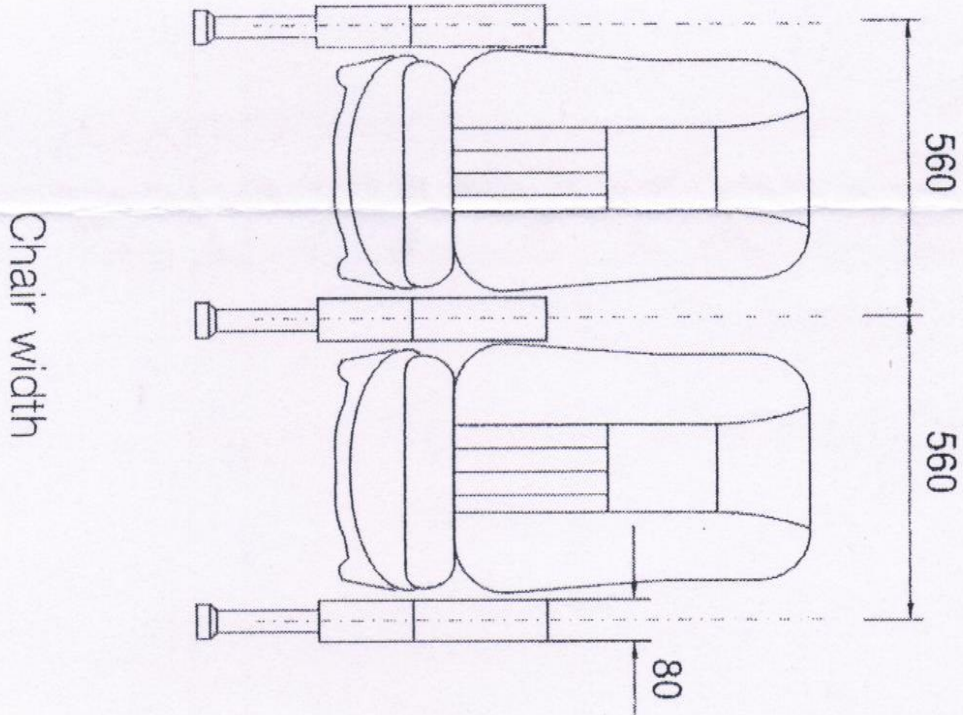

SPECIFICATIONS:

1. Metal mesh structure is a combination of 'C' channels and Rectangular MS Powder coated with 50 micron (minimum) frames (HRCA/CRCA) Sheet Metal/IS: 1079 1994 (Type O) and Side wings made of upholstered plywood.
2. Metal mesh Structure is integrated with Fluimatic Slider mechanism – a unique mechanism with triple action of push back + forward slide of the seat + auto tip-up of seat (synchronous movement of seat and back in ratio of 1:2:3)
3. Auto tip up mechanism is enabled with high performance torsion spring (Spring Steel IS:4454 1981 GRADE 3) tested for 5 lac cycles.
4. **Push back mechanism** is enabled by high performance coil springs (Spring Steel IS: 4454 1981 GRADE 2) tested for 1 lac cycles.
5. The back and seat housing comprises of High performance (PPCP IS: 10915 1994) injection Moulded Thermoform Plastic.
6. Armrest: 25mm solid wood, baking finished duly polished after dryness by dehydration.
7. Seat & Back Foam: The polyurethane foam with density 50 ± 5 kg per cubic meter and Hardness 20 ± 2 on Hapden machine at 13% compression.
8. Fabric: Heavy duty 100% polyester dyed yarn with $3\text{mm} \pm 0.5\text{mm}$ foam backing resultant.
9. Writing Pad: 300mm x 300mm x 18mm PLB: ISI Mark-ISI2823/2013 & CR-I Grade 304 IS:513 edges covered with 2mm PVC edge binding tape. Writing pad hinged by 2' x 4' MS Power coated with 50-micron (minimum) hinge fixed on 6 screws to open arm rest. The writing pad goes inside the recess of leg.
10. Grouting: The chair shall be fixed on to the floor with suitable grouting.

PRE-QUALIFICATION CRITERIA:

1. Bids will be accepted from Registered firms / Companies. Documentary evidence to this effect shall be enclosed.
2. Bids from authorized Dealers/Distributors shall be accepted provided they have a specific authorization certificate issued by the manufacture to Quote for NIT Warangal against the present Tender Notice i.e. NITW/CS-2/2018-19, dated 31-05-2018 (original copy shall be enclosed).

3. Two orders of a total Qty. of 1500-2000 Nos. or one order of 2500-3000 Nos. of above item should have been executed in any one of the financial year i.e., 2015-16 or 2016-17 or 2017-18. Satisfactory performance certificate issued by the firm i.e., Govt./Semi Govt./Autonomous/PSU only to whom the supplies were made shall be enclosed.
4. The firm should have sold worth of Rs.50.00 lakhs same or similar items at least in any of during the last three financial years i.e., 2015-16 or 2016-17 or 2017-18. Documentary evidence to this effect shall be enclosed.
5. Annual Turnover of One Crore or more on the sale of New & Unused any Furniture items for the three financial years as per the format give at Annexure-IV.
6. **The sample shall be submitted along with the bidding document i.e. on the same date & time of the closing time of Tender Box. Further, the price-bid of those firms which satisfy the all criteria including the samples only will be opened.**
7. Also, the Institute reserves the right to visit the firms for its eligibility criteria etc. at any time before placing in the Purchase Order.
8. Declaration of manufacturer with respect to material used in the item.
9. All the samples shall be supplied on free of cost including transportation “to & fro”.
10. Delivery schedule as given below:

Sl. No.	Qty.	Delivery period
1	2000 to 2500	July, 2 nd week
2	Balance will be	Aug. / Sep.

11. Warranty: One year (Minimum).

EMD-Rs. 5,00,000/-

Signature

Name: _____

Designation: _____

of the competent authority of the firm

Date & Seal

Annexure – I
(to be enclosed as age – 01)

Table of contents

Sl. No.	Description	Page No.
01	Certificate regarding page numbering	02
02	Registration and Tax clearance certificate of the supplier issued by the competent authority.	
03	GST Registration Number with percentage of Tax without any concession. (a certified true copy shall be enclosed).	
04	Registered Firms / Companies with proven track record and experience of 05 years in the supply of Seminar Hall Chairs.	
05	Make and Model number of the item together with Technical Literature / Brochures / Catalogues for the item quoted and list of Clientele.	
06	Financial Bid in a separate envelope. The envelope shall be sealed and titled as Financial Bid for _____ (mention the name of the item) and shall carry the name and address of the firm. as per the format given	
07	Annual Turnover of the firm as per the format given	
08	Bank details of the Tenderer as per the format given	
09	Declaration Certificate (shall be the last page)	

Annexure -II
(Format for certificate of page numbering &
To be enclosed as page No.02)

(Shall be on Company's Letter Head only)

CERTIFICATE

Certified that this bid document is carrying _____ pages (in figures and words) and each page is numbered.

Signature

Name: _____

Designation: _____

of the competent authority
of the firm

Date & Seal

Annexure – III
(Format for Financial Bid)

(To be enclosed in a separate envelope and shall be sealed. The Words ‘FINANCIAL BID’ shall be annotated on the enveloped)

(Shall be on the Company’s Letter Head only)

FINANCIAL BID

Name & Description of the item: _____

HSN Code No. _____

Basic Price	Discount	Packing & Forwarding	Freight	Taxes & Duties	Insurance	Any other cost*	Total Landed Cost FOR destination price per piece (Including Installation and Commission) in INR
(1)	(2)	(3)	(4)	(5)	(6)	(7)	Figures and words*
				GST @ _____%			

* Each one in Figures (inclusive of all taxes) : _____

*In words Rupees _____

Gross Total(Inclusive of all): (Qty. X price for each one): in Figures: Rs. _____

In words: Rupees: _____

Signature

Name: _____

Designation: _____
of the competent
authority of the firm

Date & Seal

Annexure-IV

(Format for Annual Turnover)

(Shall be on the Company's Letter Head only)

ANNUAL TURNOVER

Sl. No.	Annual turnover w.r.t. Furniture item(s)			Remarks if any
	2015-16	2016-17	2017-18	
(1)	(2)	(3)	(4)	(5)

Certified that the authenticity of the above has been verified by me and are correct in all respects.

Signature

Signature

Name: _____

Name: _____

Designation: _____

of the competent
authority of the firm with seal

of the Chartered Account
with seal

The relevant documents are enclosed as Page Nos. _____

Certified copies of ITRs are enclosed as page Nos. _____

Note:

- i) Documentary evidence shall be submitted along with the format
- ii) Certified copies of ITRs of the above years shall be enclosed. However, based on Provisional Statements Certified by Chartered Accountant for the financial year 2017-18.

Annexure V
(Format for Bank details)

Bank details of the Tenderer for Refund of EMD & for making payment in case L-1

Name of the Beneficiary (fill in Capital Letter) As per Bank account														
Bank Account No. (Beneficiary)														
Name of the Bank:														
Name of the Branch:														
IFSC Code of the Branch														
Swift Code/BIC Code (if needed)														
PAN No.														
Mobile No.														
Email ID:														

Signature

Name: _____

Designation: _____
of the competent authority of the firm

Date & Seal

(Format for declaration &
to be enclosed as last page of the bid document)

(Shall be on the Company's Letter Head only)

DECLARATION

I/we hereby solemnly declare and affirm that the above documentary evidence/declarations are true and correct to the best of my knowledge and beliefs. No part of it is false and nothing has been concealed therein.

Signature

Name: _____

Designation: _____
of the competent
authority of the firm

Date & Seal

PLEASE PASTE THIS SLIP ON YOUR ENVELOPE

Enquiry No. & Date: **NITW/CS-2/2018-19, dated 31-05-2018**

Name of the Item(s): **Seminar Hall Chairs**
(as mentioned in the Enquiry)

Due Date: 18-06-2018

To

**TENDER BOX
C/o. DIRECTOR
National Institute of Technology
WARANGAL -506 021 (T.S.)**

From : _____

